

Job Name:	Location:	Date:
Purchaser:	Engineer:	
Submitted to:	For <input type="checkbox"/> Reference <input type="checkbox"/> Approval <input type="checkbox"/> Construction	
Unit Designation:	Schedule No.:	

GENERAL FEATURES

- Wall-mounted indoor unit for residential applications
- Compact side discharge outdoor unit
- Zone control
- Quiet operation for both indoor and outdoor units
- "Powerful Mode" function permits system to temporarily run at a lower/higher temperature with an increased fan speed, which quickly brings the room to the optimum comfort level
- Wireless remote controller is included
- Indoor unit powered from outdoor unit using A-Control
- Automatic restart following a power outage
- Self-check function — onboard diagnostics
- Dry Mode function is standard
- Limited warranty: five years on parts and defects and seven years on compressors

OPTIONAL ACCESSORIES
Indoor Unit

- M-NET Control Adapter (MAC-3991F)
- MA Contact Terminal Interface (MAC-3971F)
- Wired Remote Controller (PAR-21MAA; requires MAC-3971F)
- Condensate Pump (230V; S13100-230)
- Anti-allergy Enzyme Filter (MAC-415FT)
- Three-pole Disconnect Switch (TAZ-MS303)

Cooling*

Rated Capacity 15,000 Btu/h
 Minimum Capacity 3,100 Btu/h
 SEER 16.0
 Total Input 1,690 W
 * Rating Conditions (Cooling) - Indoor: 80°F (27°C) DB, 67°F (19°C) WB;
 Outdoor: 95°F (35°C) DB, 75°F (24°C) WB.

Power Supply 208 / 230V, 1-Phase, 60 Hz
 Breaker Size 15 A

Voltage

Indoor - Outdoor S1-S2 AC 208 / 230V
 Indoor - Outdoor S2-S3 DC 12-24V
 Indoor - Remote Controller Wireless

OPERATING RANGE

		Indoor Intake Air Temp.	Outdoor Intake Air Temp.
Cooling	Maximum	90°F (32°C) DB, 73°F (23°C) WB	115°F (46°C) DB
	Minimum	67°F (19°C) DB, 57°F (14°C) WB	14°F (-10°C) DB



Indoor Unit: MSY-A15NA



Wireless Remote Controller



Outdoor Unit: MUY-A15NA

Indoor Unit

MCA 1.0 A
 Fan Motor 0.76 F.L.A.
 Airflow (Lo - Med - Hi - Powerful)
 Cooling 268 - 328 - 381 - 419 Dry CFM
 240 - 293 - 342 - 376 Wet CFM

Sound Pressure Level (Lo - Med - Hi - Powerful)
 Cooling 34 - 40 - 45 - 47 dB(A)

DIMENSIONS	UNIT INCHES / MM
W	30-11/16 / 780
D	8-1/4 / 210
H	11-3/4 / 299

Weight23 lbs. / 10 kg
 External Finish Munsell No. 3Y 7.8 / 1.1
 Field Drainpipe Size O.D. 5/8" / 15.88 mm
 Remote Controller Wireless

Outdoor Unit

Compressor DC-driven Inverter Twin Rotary
 MCA 14 A
 Fan Motor 0.52 F.L.A.
 Sound Pressure Level
 Cooling 50 dB(A)

DIMENSIONS	INCHES / MM
W	31-1/2 / 800
D	11-1/4 / 286
H	21-5/8 / 549

Weight 88 lbs. / 40 kg
 External Finish Munsell 3Y 7.8 / 1.1

Refrigerant Type R410A
 Refrigerant Pipe Size O.D.
 Gas Side 1/2" / 12.7 mm
 Liquid Side 1/4" / 6.35 mm
 Max. Refrigerant Pipe Length 65 ft. / 19 m
 Max. Refrigerant Pipe Height Difference 40 ft. / 12 m
 Connection Method Flared

DIMENSIONS: MSY-A15NA & MUY-A15NA

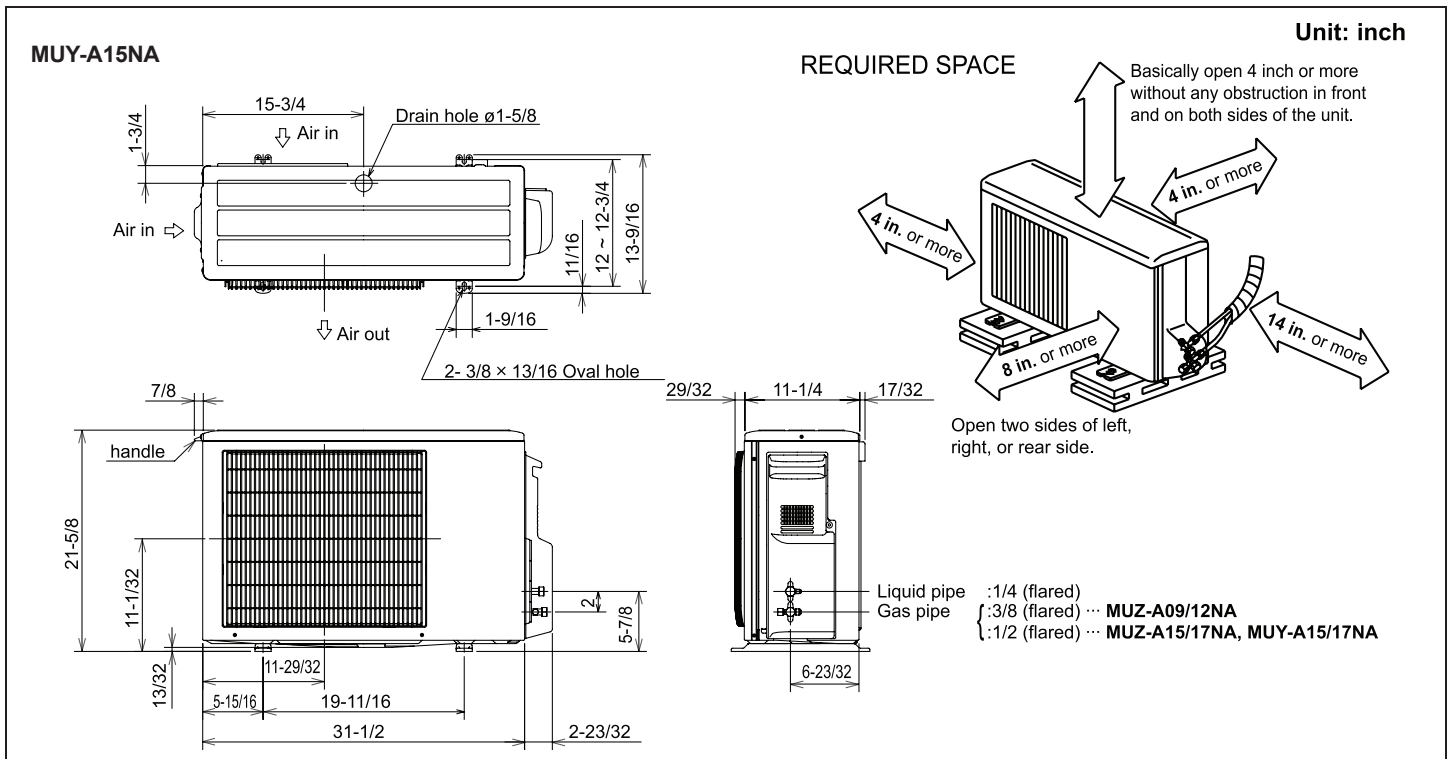
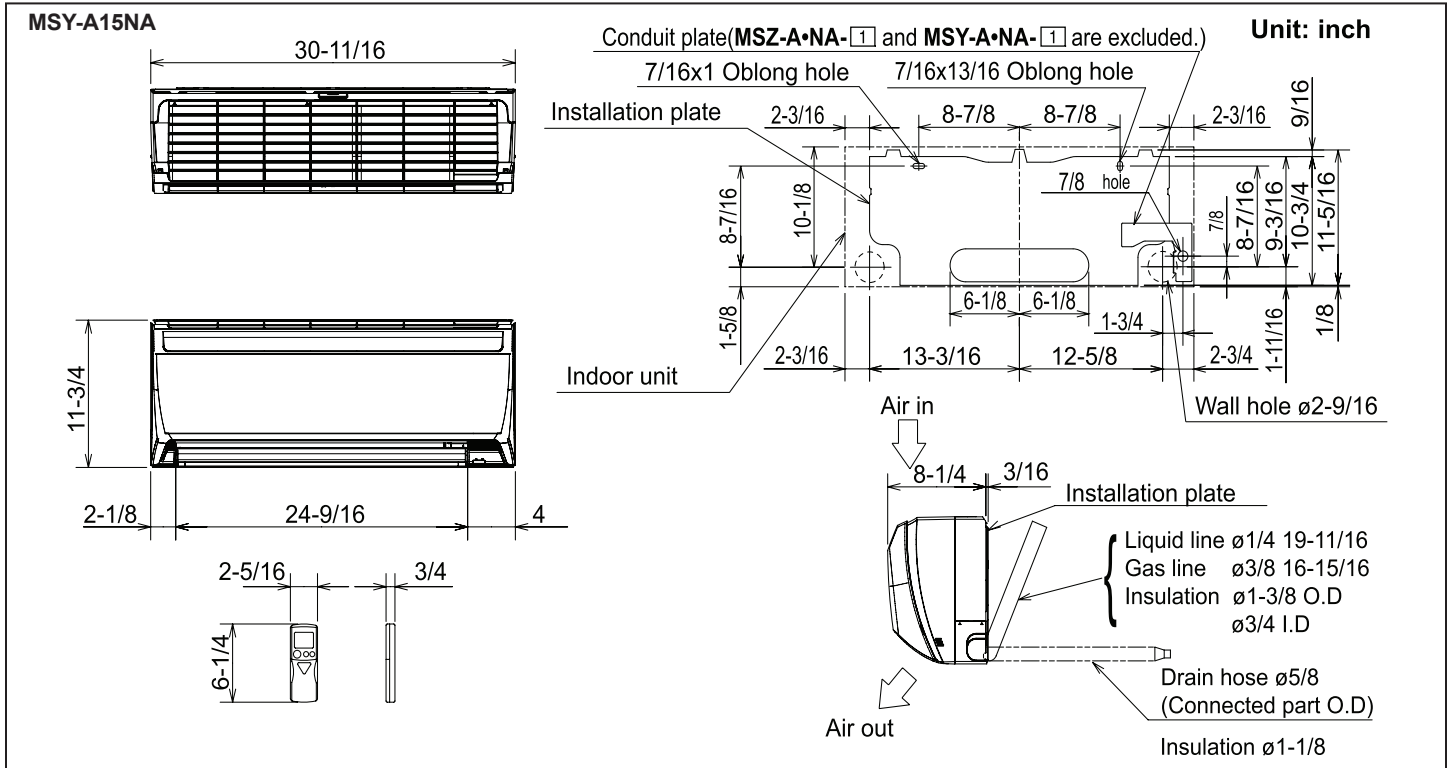

HVAC Advanced Products Division
3400 Lawrenceville Suwanee Rd
Suwanee, GA 30024
Tele: 678-376-2900 • Fax: 800-889-9904
Toll Free: 800-433-4822 (#3)
www.mehvac.com
Specifications are subject to change without notice.