



Multi Zone Specification

AUU9RML Multizone Cassette

THE POSSIBILITIES ARE INFINITE

Job Name: _____
 Location: _____
 Engineer: _____
 Submitted to: _____
 Submitted by: _____

Approval: _____
 Date: _____
 Construction: _____
 Unit #: _____
 Drawing #: _____
 Reference: _____

Power	V/Hz/P	230/60/1
Fan type		Turbo
No. Motors	(W)	42-1
CFM	(Hi,Me,Lo,Qu)	318/288/259/230
Sound Pressure Level	db (Hi,Me,Lo,Qu)	33/31/29/26
F.L.A.	(A)	.15
Refrigerant		410A
O.D. Discharge	in (mm)	1/4" (6.35)
O.D. Suction	in (mm)	3/8" (9.52)
Dimensions		H x W x D
Unit Uncrated	(in)	9-21/32 x 22-14/32 x 22-14/32
	(mm)	(245x570x570)
Unit Crated	(in)	10-7/16 x 28-3/4 x 24-19/32
	(mm)	(265x730x625)
Panel Uncrated	(in)	1-15/16 x 27-9/16 x 27-9/16
	(mm)	(49x700x700)
Panel Crated	(in)	4-23/32 x 30-1/8 x 29-23/32
	(mm)	(120x765x755)
Weight		
Unit Net	lbs. (kg)	33 (15)
Unit Gross Shipping	lbs. (kg)	40 (18)
Panel Net	lbs. (kg)	5.7 (2.6)
Panel Gross Shipping	lbs. (kg)	10 (4.5)

Cooling Capacity	(BTU/h)	9,500 (5,100-11,300)
Moisture Removal	pt/h (l/h)	1.9 (.9)
Heating Capacity	(BTU/h)	11,000 (5,100-13,000)
Temperature Setting Range		
Cooling	°F(°C)	64~90 (18~32)
Heating	°F(°C)	60~80 (16~31)
Drain Pipe Size	OD in (mm)	Ø1 (25.4)
	ID in (mm)	Ø3/4 (19.4)
Condensate Pum Lift*	in (mm)	28 (700)
Remote Control Type		Wired (Wireless Optional)
Electrical Connection**	AWG	14/3 with ground

*Pump is capable of providing 28" of lift at no more than 6" away from the unit. Lift is measured from the suction of the pump which is located at the bottom of the unit and not the outlet of the condensate.

**Power and communication are fed from the outdoor unit.

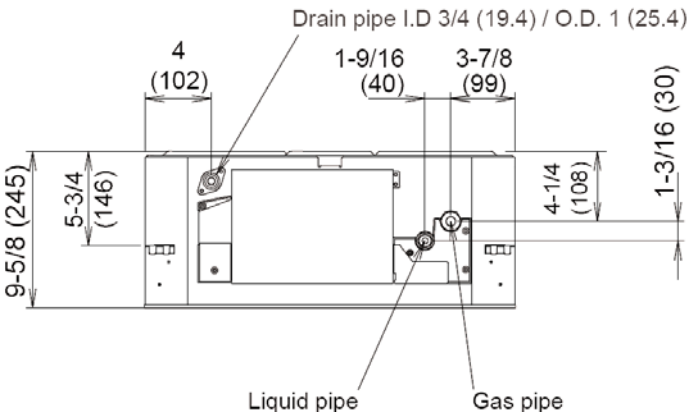
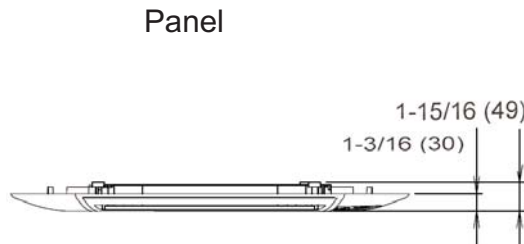
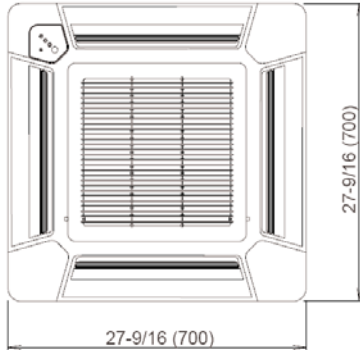

Unit

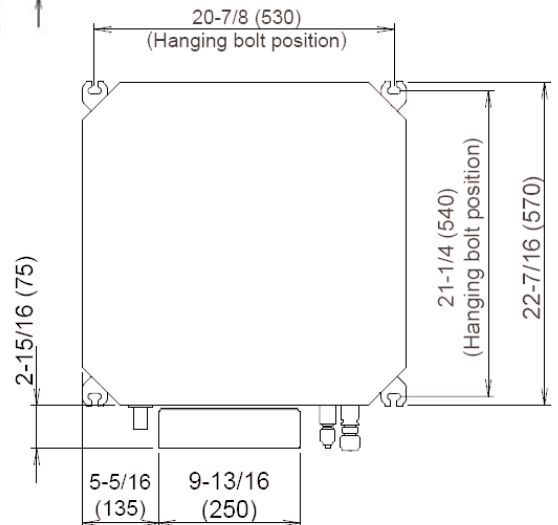

Fujitsu General America, Inc.
 Fairfield, NJ 07004
 Toll Free: 1-888-888-3424
 Fax: (973) 836-0447
 www.fujitsugeneral.com

Note:
 Specifications are based on the following conditions.
 Power source of specifications : 230V
 Cooling: Indoor temperature of 80°F(26.67°C)DB / 67°F(19.44°C)WB, and outdoor temperature of 95°F(35°C)DB/75°F(23.89°C)WB.
 Heating: Indoor temperature of 70°F(21.11°C)DB / 60°F(15.56°C)WB, and outdoor temperature of 47°F(8.33°C)DB/43°F(6.11°C)WB.
 Pipe length : 24ft. 7in.(7.5m),Height difference : 0 ft.(0m) [Outdoor unit - Indoor unit]
 Fujitsu products are subject to continuous improvements. Fujitsu reserves the right to modify product design, specifications and information in this data sheet without notice and without incurring any obligations.